

2 PC Class 150 Flanged Ball Valve (1/2" – 4")

VB2F: Class 150

FULL BORE

FACE TO FACE: ANSI B16.10

ISO 5211 ACTUATOR MOUNTING FLANGE

FLANGE: ANSI B 16.5 CLASS 150

ANTI STATIC DEVICE & BLOW OUT PROOF STEM

FIRE SAFE DESIGN

TESTING TO API 598

LOCKING DEVICE

SEAT/SEAL: 15% REINFORCED GLASSFIBER PTFE

TEMP RANGE -20 – 200 DEG C



ENERGY VALVES

NO	PART NAME	MATERIALS		
1	BODY	CF8M	CF8	WCB
2	CAP	CF8M	CF8	WCB
3	BALL	S/S 316	S/S 304	S/S 304
4	STEM	S/S 316	S/S 304	S/S 304
5	GASKET	15% GLASS FILLED PTFE		
6	SEAT	15% GLASS FILLED PTFE		
7	THRUST WASHER	PTFE		
8	PACKING	PTFE		
9	GLAND	S/S 304		
10	STEM WASHER	S/S 304		
11	STEM NUT	S/S 304		
12	HANDLE	S/S 304		
13	BOLT	S/S 304		
14	PLASTIC COVER	PLASTIC		

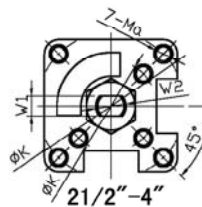
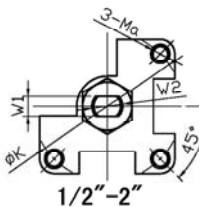
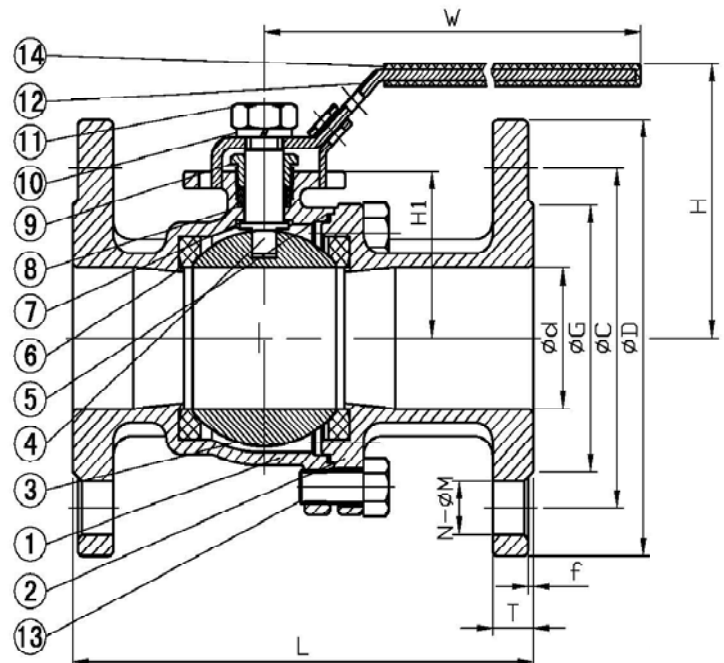

DIMENSIONS

SIZE	d	D	C	G	f	T	N	M	L	H	H1	K	ISO 5211	Ma	W	KGs
1/2"	15	89	60.5	35	1.6	12.1	4	16	108	72	27.7	36	F03	M5	123	2.5
3/4"	20	98	70	43	1.6	12.1	4	16	117	76	32.1	36	F03	M5	123	3
1"	25	108	79.5	51	1.6	12.1	4	16	127	90	39.3	42	F04	M5	152	4.5
1 1/4"	32	117	89	64	1.6	12.7	4	16	140	95	44.5	42	F04	M5	152	5.7
1 1/2"	38	127	98.5	73	1.6	14.3	4	16	165	97	50	70	F07	M8	182	7
2"	50	152	120.5	92	1.6	15.9	4	19	178	105	58.7	70	F07	M8	182	10
2 1/2"	65	178	139.5	105	1.6	17.5	4	19	190	166	99	70/102	F07/F10	M10	285	14
3"	80	190	152.5	127	1.6	19.1	4	19	203	176	109	70/102	F07/F10	M10	285	18
4"	100	229	190.5	157	1.6	23.9	8	19	229	189	122	70/102	F07/F10	M10	285	26

Energy Valves is a division of Energy Engineered Products (Pty) Ltd.
30 Monte Carlo Crescent Kyalami Park, Midrand, South Africa

Tel: +27 11 466 1926 Fax: +27 11 466 1692 Email: sales@energyproducts.co.za Web: www.energyproducts.co.za