

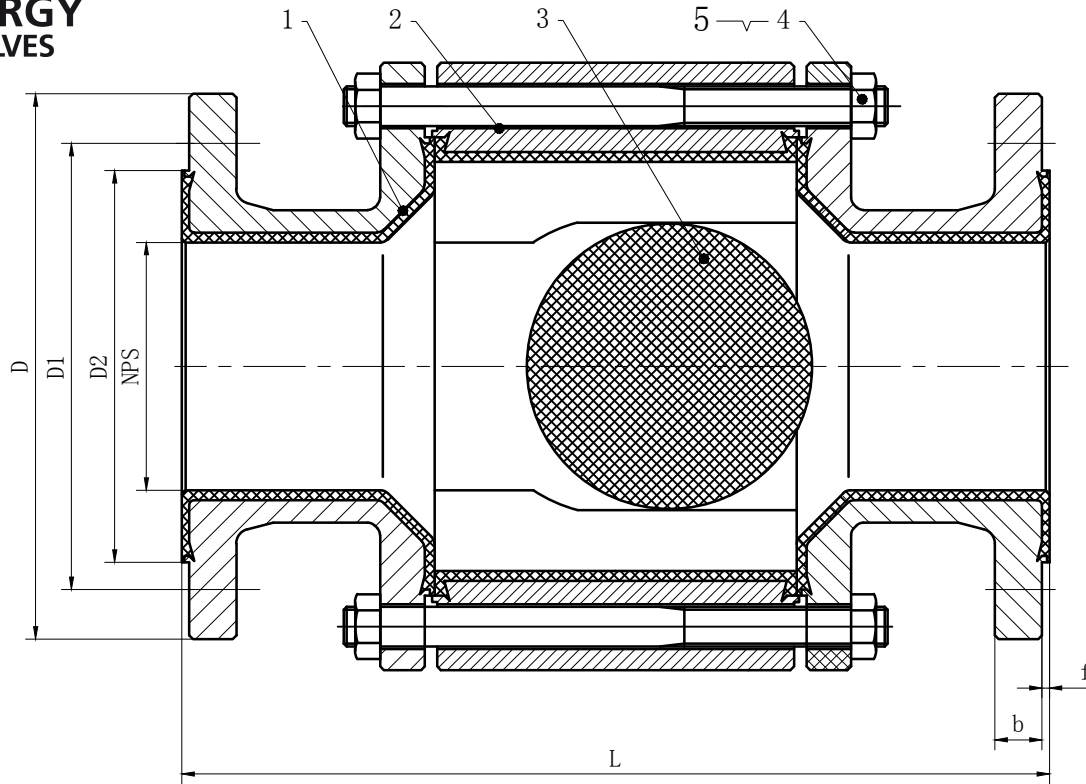

DATA SHEET REF:VCKF-150-WCB-PFA

**ENERGY
VALVES**



Standards		
Design And Manufacture	HG/T 3704	
Inspection And Test	API 598	
Face To Face Dimension	HG/T 3704	
Connection Dimension Flanged Type	ASME B16.5	
Test Specification		
Shell Test Pressure	Water	1.5 MPa
Seal Test Pressure		1.1MPa
Seal Test Pressure	Air	0.6 MPa
Spark test	15KV DC	
Suitable Working Temperature	-30~180° C	
Applicable Medium:	CORROSION MEDIUM	

NPS	L	D	D1	D2	f	b
1"	157	110	79.5	51	3	12
2"	226	152	120.5	92	3.5	14
3"	310	190	152.5	127	3.5	17
4"	350	230	190.5	157	4	19

3	Ball	PTFE			
2	Body	A216 WCB+PFA	5	Nut	SS304
1	Bonnet	A216 WCB+PFA	4	Bolt	SS304
NO.	NAME	MATERIAL	NO.	NAME	MATERIAL
		CUSTOMER:		Date:	Description:
		P. ORDER:		15. 03. 04	ASME B16.5
		OUR REF:		Design:QXQ	150LB
REV	DATE	BY	CHK	SPEC/TAG:	Confirm:ZXY
				REVISIONS	ITEM:
				YFM Valve Co.,Ltd	Model: H40PFA-150LB